

# Asahi AWP™ 1116 PD Processor and De-Moisturiser



## Main Features

- The AWP™ 1116 PD processor is an inline processor for customer with a max. of 3 plates inside the machine with maximal plate size 42x60 inch/106,7x152,4 cm.
- The machine is using approx. 12 litre per m<sup>2</sup> of water with 6% of a washout detergent. Water is re-used in a loop which is underpinning our environmental philosophy to drive print forward in balance with the environment.
- The processing temperature is approx. 40°C. Therefore dimensional plate stability is of high accuracy.
- Round brushes with oscillating motion allow uniform wash out of AWP™ plate
- A PLC control is reducing operator handling and time consuming tasks such as the dosing operation.
- A colour touch screen is showing the live process flow and component activity for easy tracking
- The integrated drying tunnel allows the skipping of the drying process and is making the plate available for the subsequent finishing process.
- Easy maintenance access is reducing machine downtime. All components have been selected with great care and can be reached easily without use of special tools.
- The processor is fitted with sensors to record the life (time and cycles) of the major components. This feature is used to apply predictive maintenance of each component in conjunction with the manufacturer's recommendation.
- CE tested
- Stainless steel frame for easy cleaning

# Asahi AWP™ 1116 PD Processor and De-Moisturiser

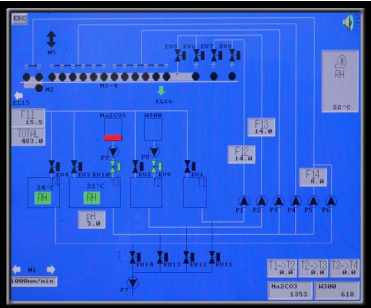

Automatic control of wash out solution with additional system of new wash out solution

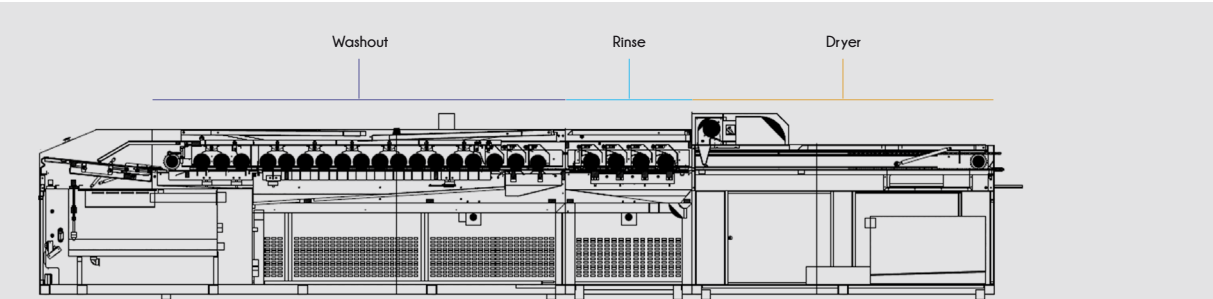

■ Technical data AWP™ 1116 PD

Maximal plate size:	42x60 inch/106,7x152,4 cm
Dimensions of system (w x l x h):	1984 x 5945 x 1190 mm
Weight of system:	2219 kg
Compressed air:	6 bars minimum
Exhaust :	840 m3/h minimum
Power supply :	400V   3Ph / N / PE   50/60Hz   26 KW   38 A 230V   3Ph / PE   50/60Hz   26 KW   65 A

■ Accessories needed for the connections:

Compressed air supply:	6 mm diameter hose
Exhaust:	100 mm hose
Power supply:	5 x 6mm   2 cable for the 400V configuration 4 x 6mm   2 cable for the 230V configuration
Water:	Inlet: ½" fitting Outlet: ¾" fitting Connection to filter: Hose, diameter 20 mm

**Floor space requirement:** Please ensure there will be sufficient space around the machine for safe use as well as easy access for maintenance. 1.5 meter free space is needed in front and at the back of the machine to give an easy access. On the sides of the unit 800 mm are requested to allow the access.

**Connections Location:** All the connection points are located inside the machine (water connection, electrical connection, compressed air connection have to be carried out going under the frame of the unit).