

# CORONA & PLASMA

FOR CONVERTING



# Corona & Plasma for **CONVERTING**

The Corona surface treatment is essential in converting processes. A quality Corona is necessary to ensure that perfect laminating and printing result we all want to see when looking at products at the end of the production line. Therefore our Corona-Plus systems are not only designed for our converting customers, but also for our customers' customers, as our Corona-Plus systems help you obtain a flawless and long lasting quality print and lamination.

Often our converting customers discover that batches of incoming material have low dyne level (surface adhesion) or that the dyne level of the material on stock has decreased due to heat or humidity. Due to the low dyne level the printing press or laminator cannot run at full speed.

In converting processes our Corona systems are used for boosting already treated materials to create high adhesion ability and a fresh clean surface that is receptive to ink, glue and lacquering.

Optionally, difficult to treat materials can be applied a Plasma treatment in which special gasses are used in the process.

Consequently the Vetaphone Corona and Plasma treatment will lead to better print and lamination quality at higher speeds due to our functional and reliable equipment supplied worldwide.



Corona treatment = perfect adhesion



No Corona treatment = low adhesion

# Specifications

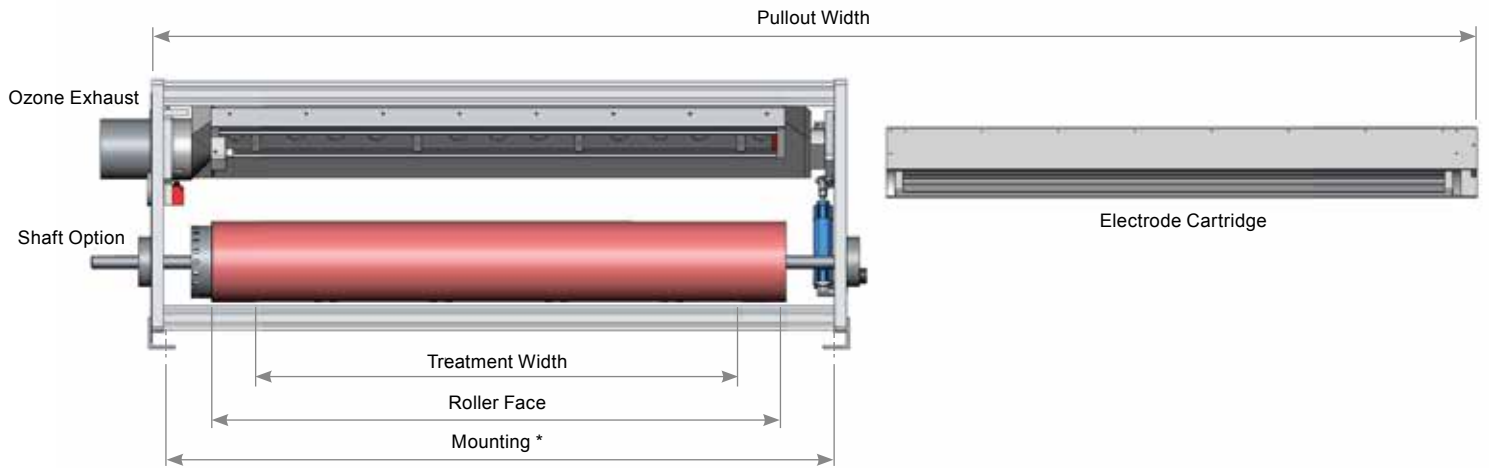

## Specifications

Widths	1000-3000 mm / 39-118 inches
Speeds	1-1600 m/min / 1-5000 f/min
Sides for treatment	1 or 2
Electrodes	Ceramic, Aluminium or Stainless Steel
Roller covering	Ceramic, Silicone or Aluminium
Roller diameter	ø200 mm / ø8 inches

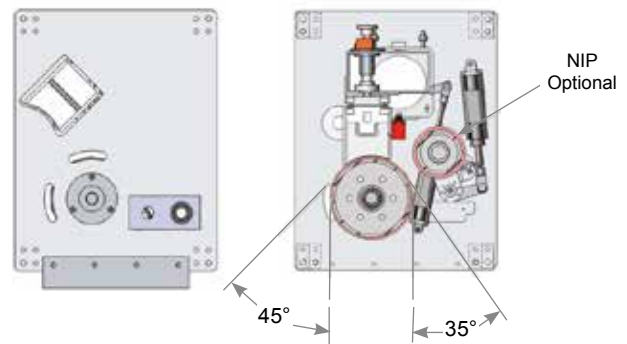

## Technical Specifications

Station	Treatment	Roller	Mounting *	Pullout
VE1C 1120	1000 mm / 39 inches	1120 mm / 44 inches	1510 mm / 59 inches	2910 mm / 115 inches
VE1C 1420	1300 mm / 51 inches	1420 mm / 56 inches	1810 mm / 71 inches	3510 mm / 138 inches
VE1C 1520	1400 mm / 55 inches	1520 mm / 60 inches	1910 mm / 75 inches	3710 mm / 146 inches
VE1C 1920	1800 mm / 71 inches	1920 mm / 76 inches	2310 mm / 91 inches	4510 mm / 178 inches
VE1C 2320	2200 mm / 87 inches	2320 mm / 91 inches	2710 mm / 107 inches	5310 mm / 209 inches
VE1C 2720	2600 mm / 102 inches	2720 mm / 107 inches	3110 mm / 122 inches	6110 mm / 241 inches
VE1C 3120	3000 mm / 118 inches	3120 mm / 123 inches	3510 mm / 138 inches	6910 mm / 272 inches

Other sizes available upon request

# Our Corona-Plus Stations for **CONVERTING**

Our Corona-Plus stations are designed for easy operation and high efficiency. Let our Corona-Plus systems give you the best Corona treatment the easiest way.



Station for Converting configured with ceramic electrodes for metallized film



Scan this QR Code and check out our video presentation

# FEATURES

# BENEFITS



## Quick Change Cartridge

The operator friendly design makes maintenance an easy task by employing the standard patented Quick Change Cartridge (QC). This ensures easy maintenance and more production time.



## Upgradeable

The VE1C series of Corona-Plus stations are designed with an upgradeable option. In case of "difficult to treat" materials or higher mechanical speed on the converting line, the model can be upgraded with other electrodes or roller types ensuring perfect adhesion at required speeds now as well as in the future.



## High Humidity Resistant

The Vetaphone Corona-Plus treaters are uniquely designed for usage in humid areas due to strict use of high quality insulators and optimum airflow extraction.



## Skip

In order to leave untreated areas at welding points, it is essential that the Corona system on printing lines is able to make intermittent treatment. The Skip system easily performs at production speeds up to 600 m/min or 1900 ft/min.



## NIP Roller

Our Corona treaters can be equipped with a NIP Roller to avoid backside treatment and ensure perfect drive control when using the treatment station as a pull station. NIP pressure is controlled pneumatically at the operator panel.



## Air Gap Adjustment

Calibrated electrode Air Gap Adjustment with digital read out ensures precise and uniform treatment of wide webs. Gives the possibility to adjust even during production.



## Extended Shaft

The Vetaphone Corona-Plus treaters can be equipped with extended shaft for direct or tendency motor drive. This option enables mounting of motor drive, i.e. in case of using thin materials.

# Our iCorona **GENERATORS**

Our series of intelligent generators, iCorona, are designed to make you forget about Corona. Let our iCorona take care of the Corona treatment, so you can focus on your core business.



## **Complete Series**

Our iCorona intelligent generator series offer outputs from 1-48 kW all based on one single generator cabinet.



# FEATURES

# BENEFITS



## Touch Control Panel

Our user friendly 10" LCD Touch control panel for the iCorona 3 and iCorona 4 provides a graphical overview of the entire Corona system. The intuitive display offers a large variety of automatic intelligent controls such as Substrate Matching, Production Log, Proportional Control, Maintenance Schedules and Digital Documentation.



## Production Log

Our iCorona generators are constantly monitoring production as regards material factor effect, speed and stops. All data are automatically stored in the iCorona display unit ready to be extracted by a USB pen for immediate analyses. Imagine that you can attach a report on the performance of the Corona system on every batch.



## Substrate Matching

Due to the patented feedback system the electrical power on the electrodes is the highest possible, giving a total equipment efficiency of minimum 95 % even during changes of substrate and additives.



## Proportional Control

The iCorona generators are all equipped with proportional control related to power and line speed to ensure a constant Watt Density. Optionally, the control panel can display either the actual generator power output in kW, or the energy delivered to the substrate in  $Wmin/m^2$  or  $Wmin/ft^2$ .



## Interface

The interfaces are used to integrate the Corona system into the complete process control making it easier for operators to control and understand the complete process line. Typically all important parameters of the Corona treatment and production data can be viewed graphically at the operator's main panel.



## Module Built

The iCorona is manufactured for optimum efficiency. All important electronic components are built into one easy accessible module. So servicing your generator is simply done by plugging in only one new part, the module. Changing the complete module is quick and will make the generator work smooth and in a longer time, as all vital parts are updated to the newest technology.

60 THE INVENTOR WITH MORE THAN **years** EXPERIENCE

## Satisfied Customers **WORLD WIDE**

“ We were attracted by the sturdy, simple construction and especially by the innovative and practical removable cartridge system, and we weren't disappointed.

The Vetaphone Corona treater immediately reduced maintenance time and costs and adding to that a very low ratio of breakdowns and failures during operation. It wasn't a hard decision to go back for more. ”

Explains Technical Manager at Hatzopoulos, Mr. Ovidios Serb, Greece.

[Read other customer statements on our website.](#)

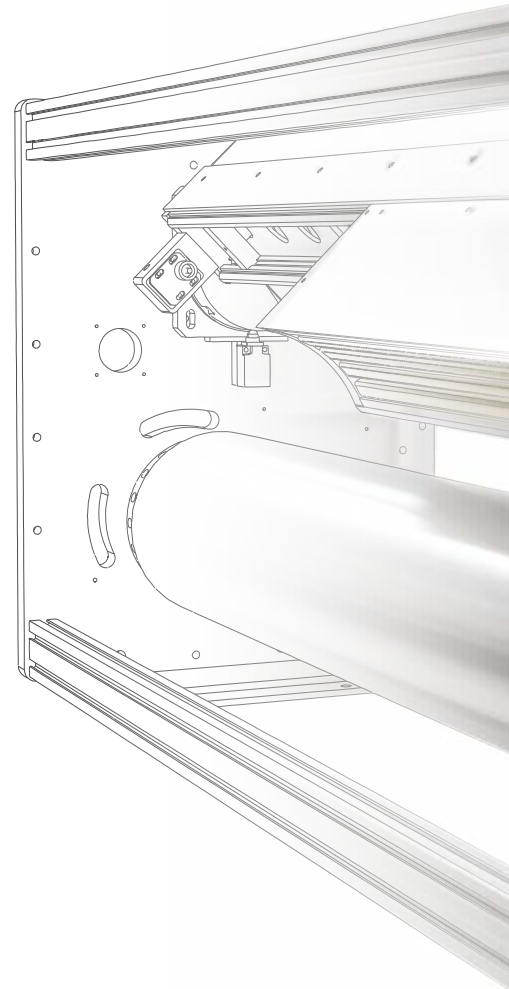

[www.vetaphone.com](http://www.vetaphone.com)

DENMARK - SINGAPORE - USA - UNITED KINGDOM - GERMANY - BENELUX - ITALY