

CORONA & PLASMA

FOR NARROW WEB



Corona & Plasma for **NARROW WEB**

The Corona surface treatment is essential in label printing. When the label is made from plastic substrate the ink tends to become blemished due to its inability to bond to the plastic. This problem occurs because the surface energy of the plastic is insufficient to permit a proper bond. A quality Corona treatment is necessary to ensure the perfect label print quality we all want to see when looking at products at the end of the production line. Therefore our Corona-Plus systems are not only designed for our customers in narrow web printing, but also for our customers' customers, as our Corona-Plus systems help you obtain a flawless and long lasting quality print.

Often, our customers discover that batches of incoming material have low dyne level (surface adhesion) or that the dyne level of the material on stock has decreased due to heat or humidity. Due to the low dyne level the narrow printing press cannot run at full speed.

As a consequence the Vetaphone Corona systems are used for boosting already treated materials to create high adhesion ability.

A common problem in the narrow web industry is the necessity for using top coated materials which have been chemically altered in order to obtain a high surface adhesion for inks. The top coated materials are more expensive to purchase than regular materials. By adding a Vetaphone Corona-Plus treater to your narrow web press, you will often eliminate the need for using top-coated materials and thereby decrease production costs significantly.

Optionally, difficult to treat materials can be applied a Plasma treatment, which on special materials can create better and longer lasting adhesion. To enable Plasma treatment the station is replaced by a special encapsulated Plasma station, where gas can be connected, thereby creating Plasma treatment.



Specifications

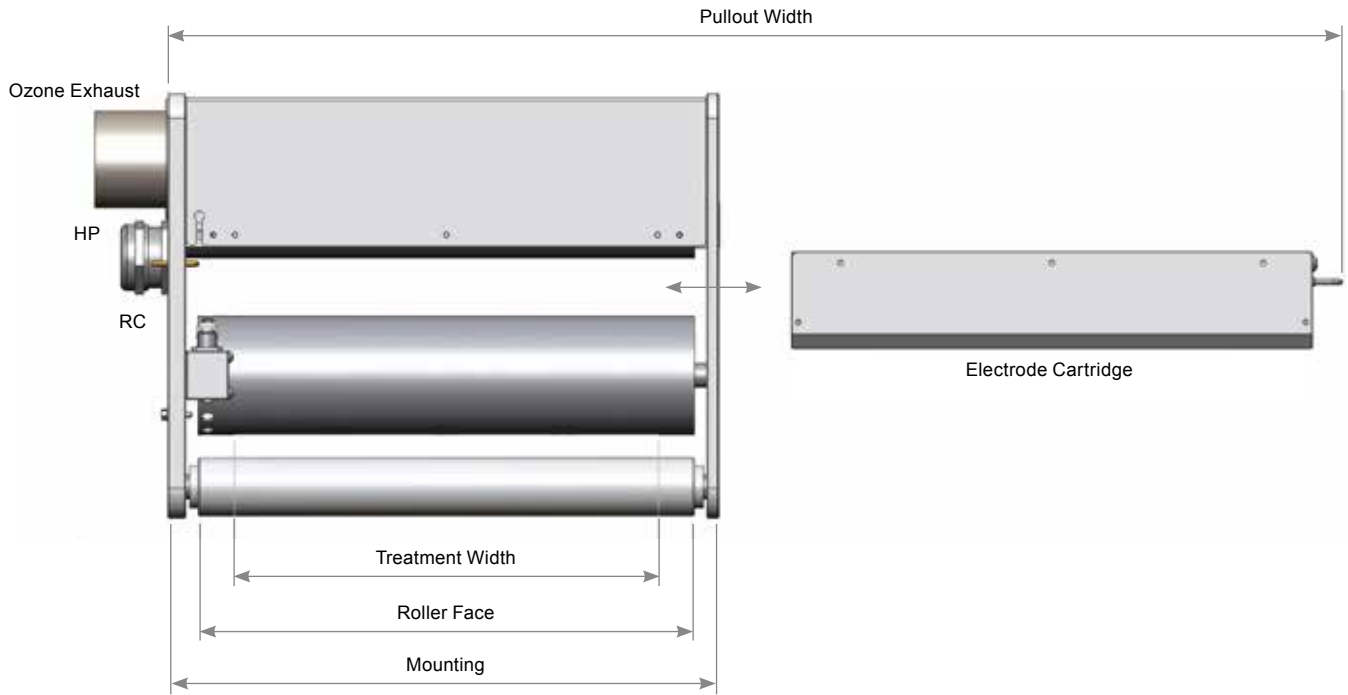

Specifications

Widths	350-860 mm / 14-34 inches
Speeds	1-400 m/min / 1-1300 ft/min
Side for treatment	1 (2 sides optional)
Electrodes	Ceramic (up to 6 pcs)
Roller covering	Stainless Steel
Roller diameter	ø100 mm / ø4 inches
Mounting	Cantilevered or Base Mounting

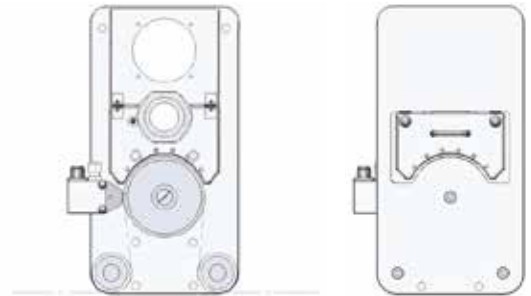

Technical Specifications

Station	Treatment	Roller	Mounting	Pullout
VE1A-A 410	350 mm / 14 inches	410 mm / 16 inches	455 mm / 18 inches	915 mm / 35 inches
VE1A-A 480	420 mm / 17 inches	480 mm / 19 inches	525 mm / 21 inches	1055 mm / 41 inches
VE1A-A 520	460 mm / 18 inches	520 mm / 20 inches	565 mm / 22 inches	1135 mm / 45 inches
VE1A-A 620	560 mm / 22 inches	620 mm / 24 inches	665 mm / 26 inches	1335 mm / 52 inches
VE1A-B 710	650 mm / 26 inches	710 mm / 28 inches	755 mm / 30 inches	1515 mm / 59 inches
VE1A-B 820	760 mm / 30 inches	820 mm / 32 inches	865 mm / 34 inches	1735 mm / 68 inches
VE1A-B 920	860 mm / 34 inches	920 mm / 36 inches	965 mm / 38 inches	1930 mm / 75 inches

Other sizes available upon request

Our Corona-Plus Stations for **NARROW WEB**

Our VE1A Corona-Plus station is designed to ensure easy operation and high efficiency.
Let our VE1A give you the best Corona treatment the easiest way.



Scan to see our product
presentation

FEATURES

BENEFITS



Quick Change Cartridge

The electrodes are placed in an easy removable Quick Change cartridge. This enables easy cleaning and changing of the complete set of electrodes in a matter of seconds, and thereby providing reduced maintenance costs and increased productivity.



Ceramic Electrodes

The Corona stations are equipped with ceramic electrodes for treatment of both electrically conductive substrates and non-conductive film. The ceramic electrode system can be upgraded from four to six highly efficient ceramic electrodes if treatment of difficult materials is required.



Rollers

All Vetaphone narrow web stations are delivered with stainless steel backing roller for optimum stability and rotating accuracy. The VE1A Corona-Plus station is typically delivered as standard with two guide rollers ensuring perfect web path of the film.



Double End Plates

To fulfil the increasing demand for precision and quality in the printing process Vetaphone has designed the VE1A station with double-end plates. This construction makes the station more robust which ensures perfect alignment and a more uniform surface adhesion on the end product.



High Humidity Resistant

The Vetaphone Corona-Plus treaters for narrow-web are uniquely designed for usage in humid areas due to strict use of high quality insulators and optimum airflow extraction.



Ozone Extraction

The units will be supplied with ozone extraction from the back or optional from the top of the station. Besides removing the ozone the extraction unit also has a cooling effect on the ceramic electrodes, giving them prolonged durability. All parts utilized in the stations are made from corrosion and ozone-proof materials.



Special Touch Control Panel Option

The VE1A Corona-Plus station is also available with a user friendly touch control panel that is integrated in the front of the VE1A. The optional touch display enables easy access to control of the station and eliminates the need for mounting of an external control panel.

Our iCorona **GENERATORS**

Our intelligent iCorona generators are designed to make you forget about Corona. Let our generators take care of the Corona treatment, so you can focus on your core business.



iCorona for Narrow Web

Our generator series for Narrow Web offers outputs from 1-6 kW all in one single generator cabinet. iCorona generators up to 2 kW have built in HP- Transformers.



Scan to see our product presentation

FEATURES

BENEFITS



TF-415 Operator Panel

Our TF-415 operator panel enables easy and user-friendly control of the Corona-Plus system. The panel features a graphical overview of the entire system, where line stops and errors quickly are located by LED indicators. The operator panel is removable and can be used for remote control.



Substrate Matching

Due to the patented feedback system the electrical power on the electrodes is the highest possible, giving a total equipment efficiency of minimum 95 % even during changes of substrate and additives.



Proportional Control

The iCorona generators are all equipped with proportional control relating power and line speed to ensure a constant Watt Density. Optionally, the control panel can display either the actual generator power output in kW, or the energy delivered to the substrate in $Wmin/m^2$ or $Wmin/ft^2$.



Air Flow Switch

To secure the correct ozone exhaust and cooling of the electrodes the iCorona system is equipped with an airflow sensor. The cooling of the ceramic electrodes ensures improved durability.



Interface

The interfaces are used to integrate the Corona system into the complete process control making it easier for operators to control and understand the complete process line. Typically all important parameters of the Corona treatment and production data can be viewed graphically at the operator's main panel.



Module Built

The iCorona is manufactured for optimum efficiency. All important electronic components are built into one easy accessible module. Thus servicing your generator is simply done by plugging in only one new part, the module. Changing the complete module is quick and will make the generator work smooth and for a longer time, as all vital parts are updated to the newest technology.

Satisfied Customers **WORLD WIDE**

“ For many years, Vetaphone has been our preferred partner when Nilpeter customers were to be advised about the Corona equipment.

The reason for this long lasting partnership is also due to the fact that Vetaphone's equipment matches the high quality standards required by Nilpeter, the reliability and last but not least the user-friendly type of equipment.

Furthermore, Vetaphone has shown an extended flexibility and service support throughout the years. ”

Explains Steen Thøisen Sales Manager at Nilpeter, Denmark.

“ Vetaphone is a key OEM supplier to AB Graphic, in the time that we have worked together their Corona treatment systems have been of a consistently high standard of quality. They have assisted us with good sales support, engineer training and technical back up providing an all round service that surpasses our expectations. I am happy to say that to date Vetaphone has been one of our best suppliers and I look forward to a long and beneficial partnership. ”

Explains David Kirkham Director at AB Graphic International, UK.

[Read other customer statements on our website.](#)

