

Specifications

	970ST-2/970PF-2	970ST-4/970PF-4	970ST-5/970PF-5	970ST-6/970PF-6	970PF-8	970PF-10	
Number of printing units	2 (2/0, 1/1)	4(4/0, 2/2)	5 (5/0, 4/1) 5 (5/0, 3/2)	6 (6/0, 5/1) 6 (6/0, 4/2)	8 (8/0, 4/4)	10 (10/0, 5/5)	
Cylinder arrangement of the convertible perfecting device	Double/double/single-diameter perfecting mechanism						
Max. sheet size	650 x 965 mm (25.59" x 38")						
Min. sheet size	970ST (straight press): 290 x 410 mm (11.42" x 16.14") 970PF (convertible perfecter): [straight printing] 290 x 410 mm (11.42" x 16.14") [perfecting] 370 x 410 mm (14.57" x 16.14")						
Max. printing area	970ST (straight press): 640 x 930mm (25.20" x 36.61") 970PF (convertible perfecter): [straight printing] 640 x 930 mm (25.20" x 36.61") [perfecting] 630 x 930 mm (24.80" x 36.61")						
Paper thickness*1	970ST (straight press): 0.04 – 0.6 mm (0.0016" – 0.024") 970PF (convertible perfecter): 0.04 – 0.5 mm (0.0016" – 0.020")*2						
Max. printing speed*3	970ST (straight press): 16,000 S.P.H., 970PF (convertible perfecter): 15,000 S.P.H.*2						
Plate size	700 x 945 mm (27.56" x 37.20") [positioning pin pitch: 780 mm (30.71")] Plate thickness (cylinder packing total): 0.48 mm (0.019")						
Blanket size	800 x 955 mm (31.50" x 37.60")						
Feeder/delivery pile capacity	Feeder: 1,100 mm (43.31") Delivery: 1,100 mm (43.31") (includes pallet height for both the feeder and delivery pile)						
Number of rollers	Ink rollers: 19 (form rollers: 4) /unit Water rollers: 4 (form roller: 1) /unit						
Non printing area	10 ± 1 mm (0.39" ± 0.039")						
Dimensions	Length*4	6,380 mm (20'11") / 7,051 mm (23'2")	8,350 mm (27'5") / 9,021 mm (29'7")	9,335 mm (30'8") / 10,006 mm (32'10")	10,320 mm (33'10") / 10,991 mm (36'1")	12,960 mm (42'6") 14,930 mm (49')	
	Width	3,098 mm (10'2")				3,453 mm (11'4")	
	Height	2,011 mm (6'7")					

*1 Printing paper thickness may vary according to paper stock. *2 For both straight printing and perfecting.

*3 The local conditions, ink and printing plate type, and the printing quality required will affect the maximum printing speed.

*4 The indicated length is for a standard delivery press (chain gripper delivery) without a coating unit and does not include peripheral devices.

Please contact an RMGT dealer or representative for detailed information on dimensions and weight for other press types.

Dimensions

970ST-4

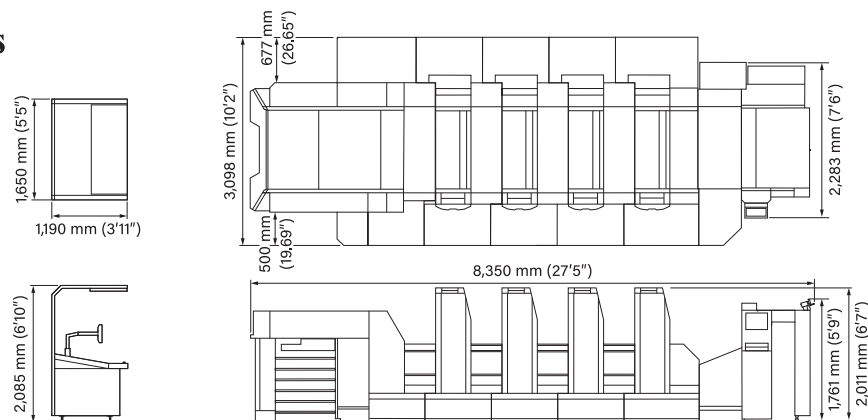

970PF-8

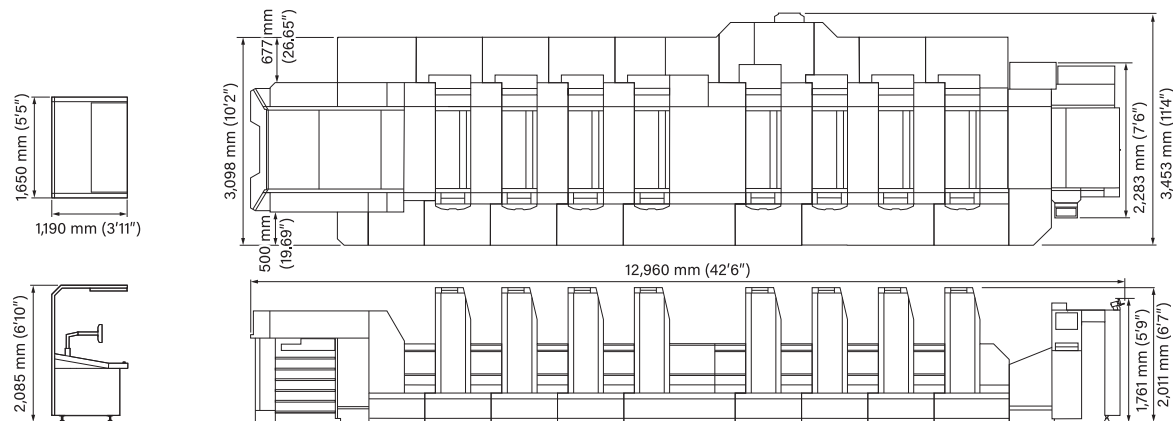

Design and specifications are subject to change without notice.

RMGT RYOBİ MHI Graphic Technology Ltd.

International Sales and Marketing Department
5-2-8 TOSHIMA, KITA-KU, TOKYO 114-0003, JAPAN
TEL. +81-3-3927-5238, FAX. +81-3-3927-5240
<https://www.ryobi-group.co.jp/graphic/>

Cat. No. 970 (P16) Feb. '22 E01 SX02

Order No. H5894 01 002

Printed in Japan

A1-plus Size Offset Presses
970 model

RMGT 9

NEW

9

RMGT

Expanded versatility and powerful, eco-friendly features

Superior economy, productivity, and profitability

Introducing the new A1-plus size RMGT 970

Greater economy, productivity, and profitability for this age of rising printing costs.

Plus a variety of eco-friendly features for a sustainable society.

Combining the low energy consumption and compact design of the 920/940 series with high-precision manufacturing technology for reliable continuous operation, RMGT's new A1-plus size offset press meets the diverse needs of printing companies in today's changing market.

Handles sheet sizes up to 650 x 965 mm for greater versatility.

A benderless plate clamp and a predictive density control system that quickly adjusts ink density shorten make-ready time.

Feeder section and delivery section touchscreen monitors provide an improved user interface. Smart Assist Printing enables automatic continuous printing of multiple jobs. These and other mechanisms and functions deliver the versatility needed to handle a wide range of jobs with the superior economy, productivity, and profitability expected of an A1-plus size press.

In addition, a perfecting device with improved sheet transport precision enables high-speed one-pass perfecting on both thin and thick stock. Combined with an LED-UV curing unit, this creates the opportunity to produce new high value-added work.

The RMGT 970 delivers outstanding performance for all types of printing and meets a wide range of needs to help printing companies succeed in a changing market.



Note: The press in the photo includes optional equipment.

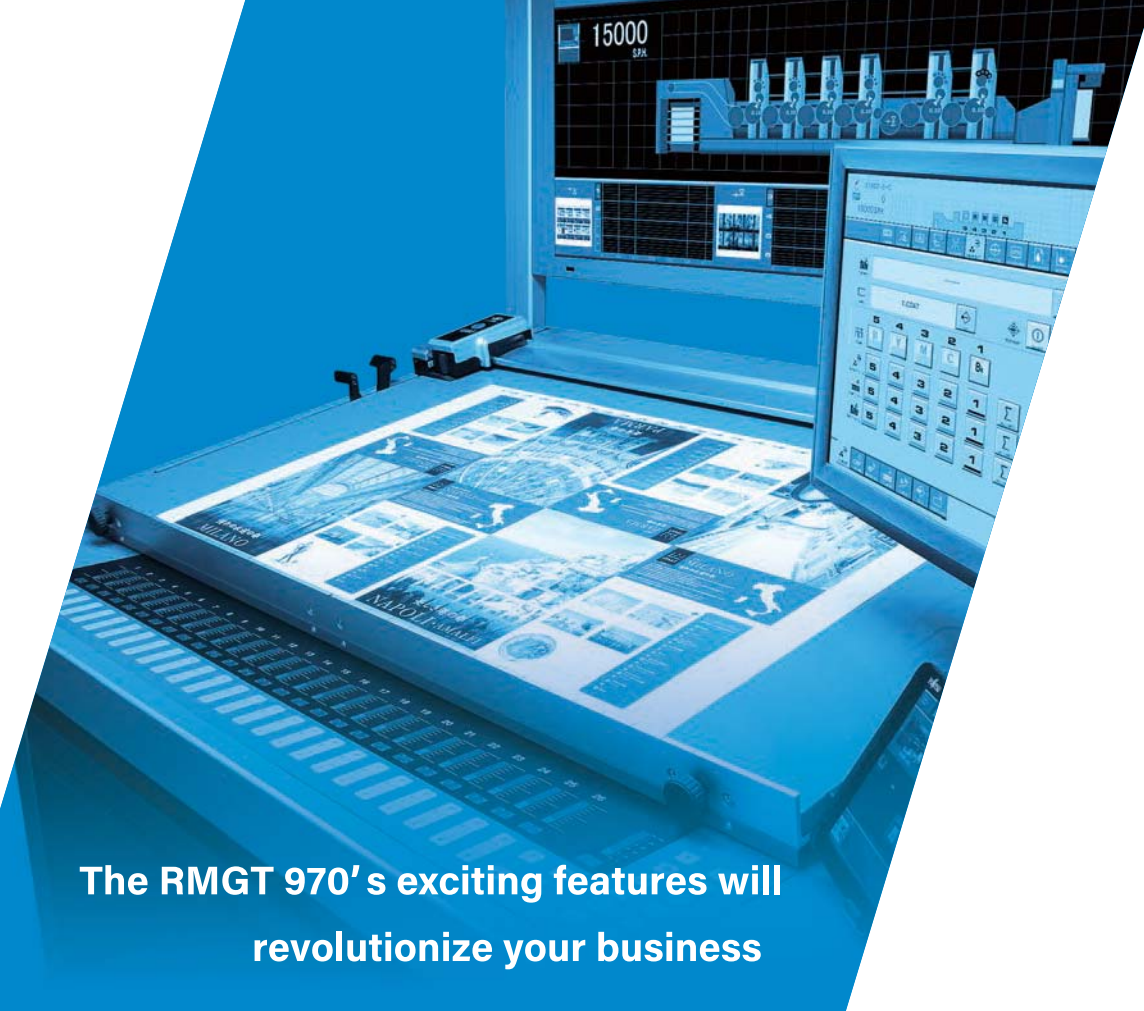

The RMGT 970's exciting features will revolutionize your business

The high cost-performance of an A1-plus size press

Ultra-short make-ready time ensures high productivity

Exceptional printing stability from thin to heavy stock

Advanced automation and labor-saving mechanisms assist the operator

Instant-drying perfecting for quick turnarounds

Varnish coating and special printing for higher added-value

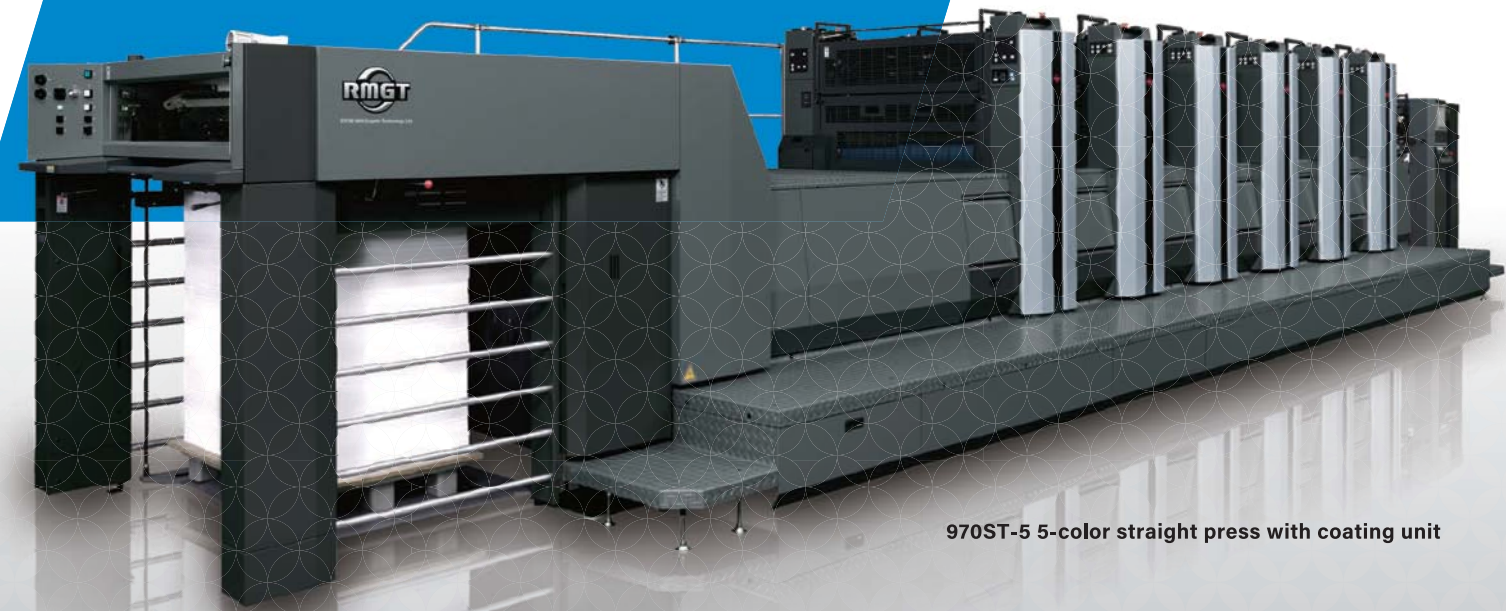

970ST-5 5-color straight press with coating unit

Exceptional Versatility and Economy

A1-plus size for a wide range of printing, including packages.

The ideal press for printing A1-plus size, the most popular size in today's market.

Reduced costs for printing materials enhances profitability.

Highly Reliable Sheet Transport

The 970's exceptionally stable transport of both thin and heavy stock markedly improves productivity.

The 970 adopts double-diameter impression and transfer cylinders with a significantly larger curvature radius than the 920 and 940 models.

The proven sheet feed and delivery mechanisms of the 920 and 940 models have been further improved,

increasing versatility for printing on heavy stock.

Full coverage of A1-plus size NEW

Perfecting is possible on sheets up to 650 mm vertically, ensuring full coverage of A1-plus size sheets [including 25 " x 38 " (635 x 965 mm) for the US market and 650 x 920 mm or 650 x 950 mm for the European market]. A maximum printing area of 630 x 930 mm provides ample space for color bars and register marks for PQS-D quality control. When straight printing, the maximum printing area is 640 x 930 mm. The 970 model can handle a wide range of applications, including poster printing and multi-up printing for irregular sizes such as packages.

[Examples of imposition]

1) When printing 8-up of letter size on U.S. popular paper 25" x 38" size

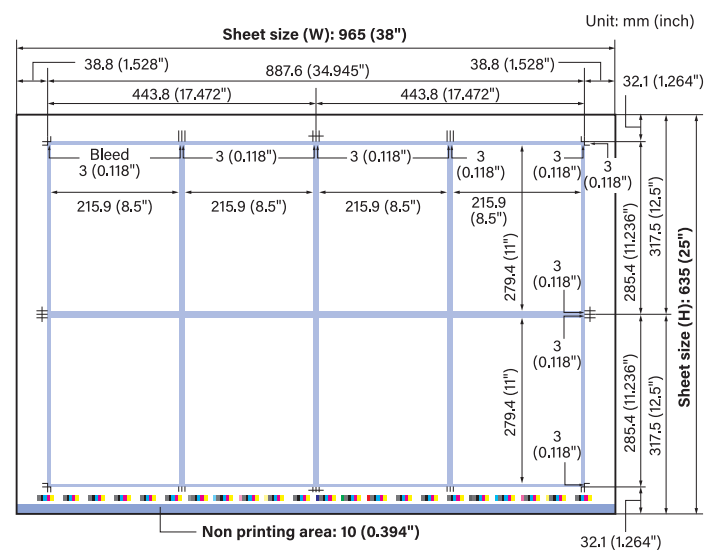

2) When printing 16-up of A5 size on the European countries popular paper 650 x 920 mm

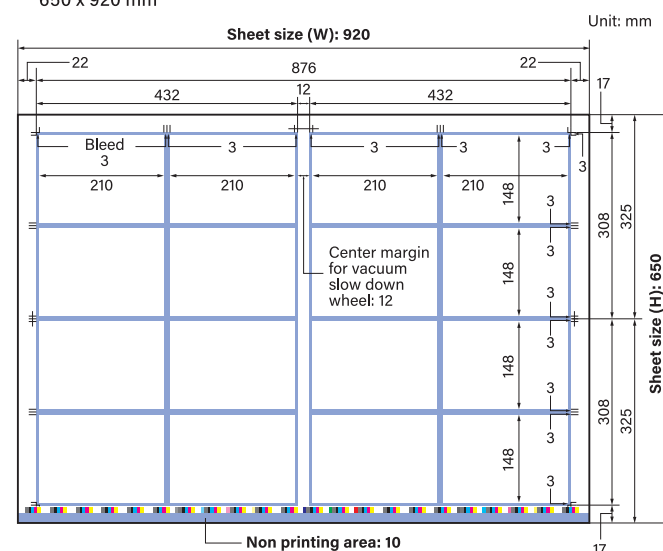

Superior economy

Compared with a B1-size press, the 970 has lower plate costs and reduced power consumption for much lower running costs.

It also features a small-footprint design for a more comfortable work environment and more efficient utilization of printshop space.

[Advantages of the 970 compared to a B1-size press*1]

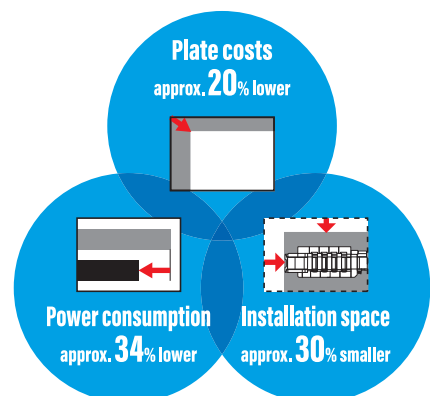

[Comparison of 970 and a B1-size press plate costs over 10 years*2]

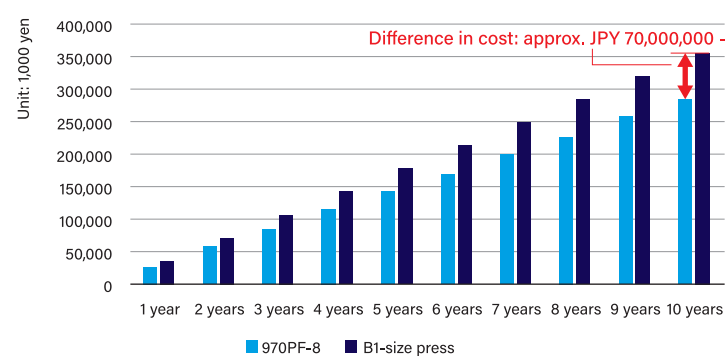

*2 Using a 970PF-8 8-color perfecter for 15 jobs per day, 23 working days per month.
 Plate size (B1-size press): 800 x 1,030 mm
 Plate cost: Calculated at JPY 1,300 /m²
 Actual results will vary depending on the specific conditions.

*1 In-house comparison: actual results will vary according to operating conditions.

Double-diameter cylinder printing mechanism

The printing units feature double-diameter impression and transfer cylinders. The curvature radius of the cylinders has been enlarged to reduce stress on sheets and prevent sheets from flapping even when printing on heavy stock or film, ensuring stable sheet transport.

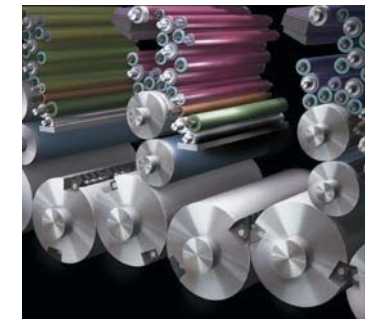

Double-diameter cylinder printing mechanism

V-type feeder

A proprietary separator mechanism employs air management for highly stable feeding of sheet thicknesses from 0.04 mm to 0.6 mm* even during high-speed operation, providing the versatility for a wider range of applications, including fliers and packages.

* 0.5 mm for perfecting



V-type feeder

Vacuum feeder board

Sheets on the feeder board are securely held in place by a vacuum suction belt, ensuring smooth sheet transport to the front lay. Simultaneous movement of the brush and runner wheels shortens the time required to change the sheet size.



Vacuum feeder board

Pneumatic side lay device*

Air suction is used to pull the sheet toward the side lay, preventing scratches on delicate materials such as film.

* Option

Delivery air guide

A shallow sheet trajectory through the press reduces the stress on the sheet. A delivery air guide further ensures stable sheet transport.



Pneumatic side lay device



Delivery air guide

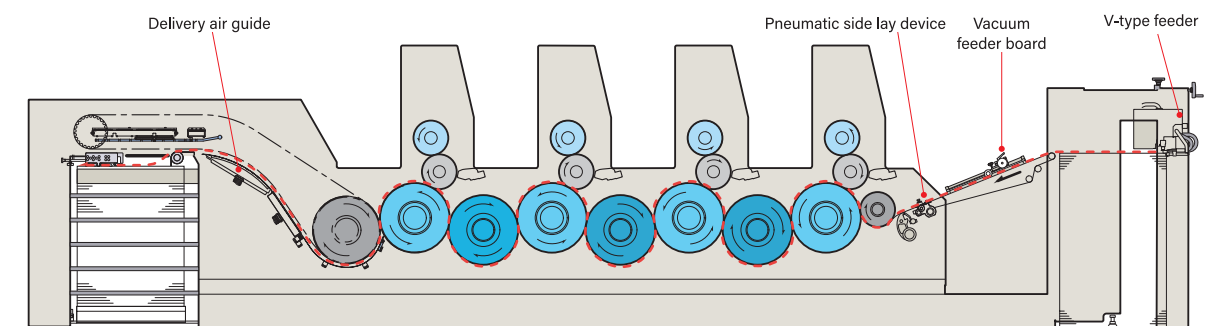

Fast Job Changeover

Ultra-short make-ready time ensures greater productivity.

The 970 features new technology for shortening make-ready time, which is key to increasing productivity.

The benderless plate clamp and a predictive density control system that quickly adjusts ink density raise productivity to an entirely new level for short-run printing.

Smart Make-Ready function

A Smart Make-Ready function that automatically performs blanket cleaning, plate changing, preset inking and test printing greatly enhances efficiency. Job changeover is shortened even further by a newly-added feature that allows blanket cleaning and preset inking (ink feeding) to be performed simultaneously. Fast job changeover further boosts productivity of diverse, small-lot printing.

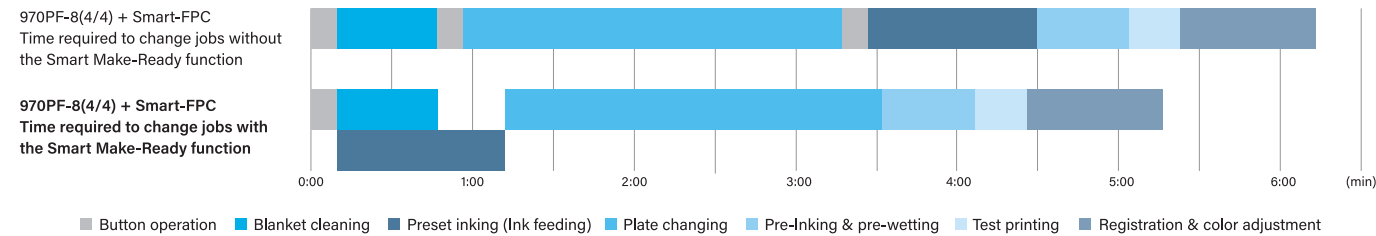

Note: The times shown were measured in-house by RMGT engineers. Actual results will vary according to the printing conditions, printing speed, and operator proficiency.

Automatic plate changing

The 970 can be equipped with the Smart-FPC fully automatic simultaneous plate changing system, FPC fully automatic plate changing system, or SPC semiautomatic plate changing system*. When changing plates with the Smart-FPC and FPC, both loading and ejection of plates can be automatically performed at the touch of a button on the touchscreen monitor of the PCS-G printing control system, enabling the operator to perform other tasks during plate changing. All three automatic plate changing systems feature benderless plate clamp, eliminating the time and labor required to bend plates.

* SPC: Standard, Smart-FPC/FPC: Option

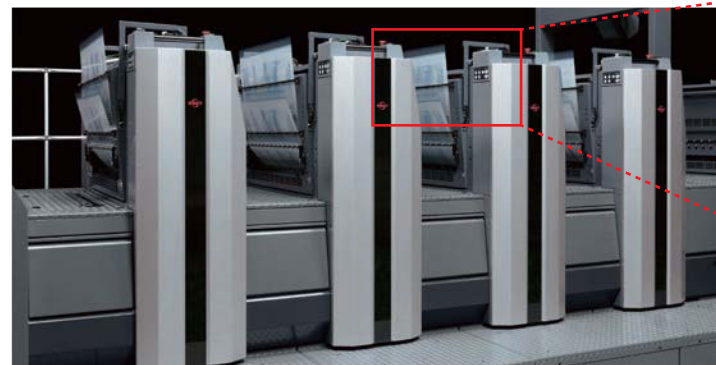

Benderless plate clamp

[Comparison of Smart-FPC and FPC make-ready times]

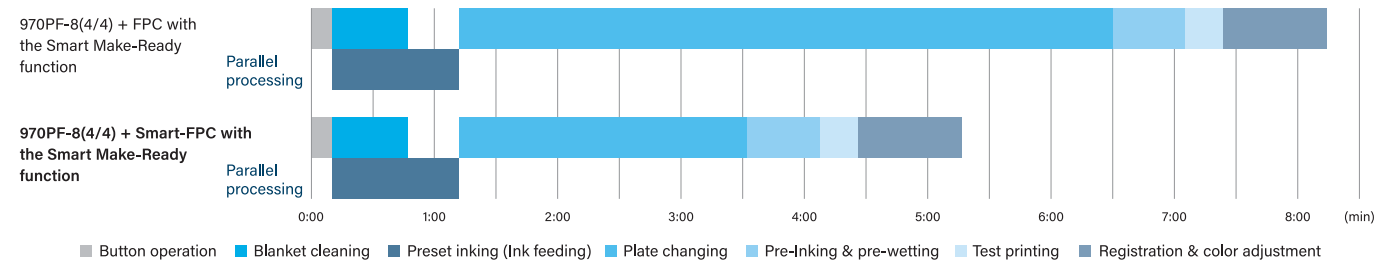

Note: The times shown were measured in-house by RMGT engineers. Actual results will vary according to the printing conditions, printing speed, and operator proficiency.

Predictive density control system* NEW

A newly developed system for quickly achieving and maintaining the target density with minimum wasted sheets. Ink density is automatically adjusted and controlled by measuring the color bar density on printed sheets and predicting the ink density. This reduces sheet waste during job changeover and maintains stable printing density.

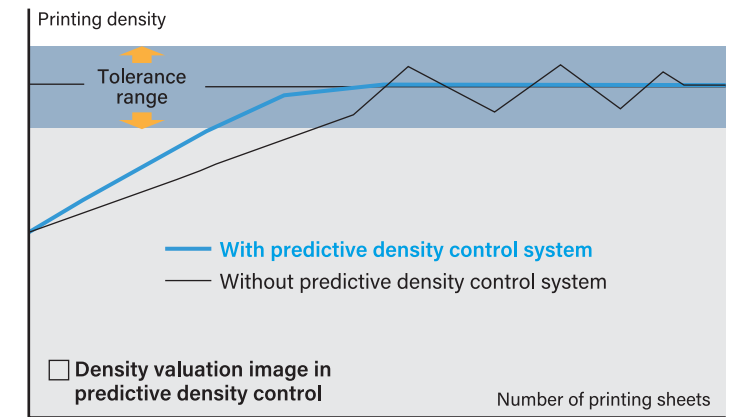
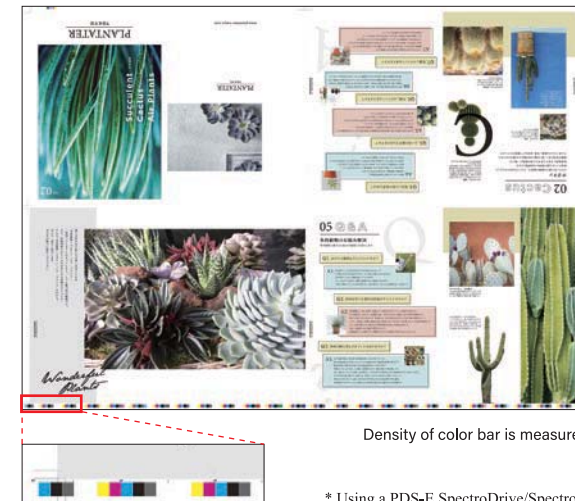

* Using a PDS-E SpectroDrive/SpectroJet printing density control system and a PQS-D printing quality control system

Program Inking

Ink is automatically supplied to match the print image. After a set number of sheets has been printed, the ink on the rollers is automatically returned to an even state to move smoothly on to the next job.

[Program Inking Flowchart]

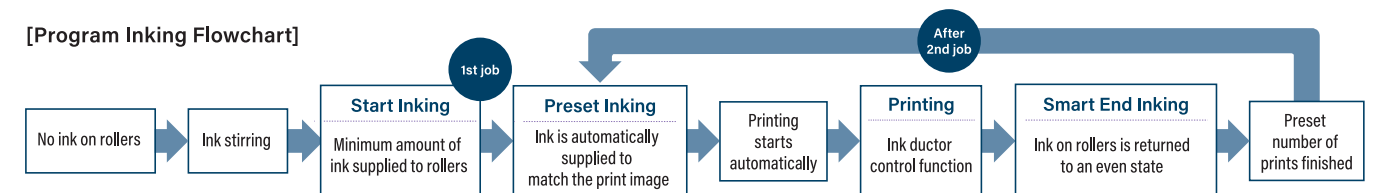

Base ink volume control function

Even with job changeover to a completely different print image, the amount of ink on the ink rollers is quickly increased or decreased to begin printing with less waiting time.

Base ink volume-down function : The ink roller cleanup attachment contacts the ink oscillating roller and reduces ink volume.

Base ink volume-up function : The ink ductor roller contacts the ink rollers to quickly increase the volume of ink on the rollers.



Base ink volume-down function screen

Feeder air presetting*

The air volume for the feeder and registration sections can be preset together from the operation stand according to the substrate type and thickness, shortening make-ready time when changing sheets. If more precise air adjustment is required, such as for printing on thin stock, fine adjustments can be made on the feeder touchscreen monitor. Updating and saving the preset values further enhances preset precision for repeat jobs.

* Option

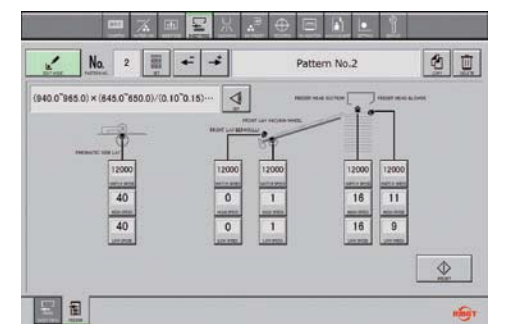

Feeder air presetting screen

One-pass High-speed Perfecting

A single press handles a wide range of both straight printing and perfecting

The RMGT 970 lineup includes a full range of models equipped with a double/double/single-diameter cylinder perfecting mechanism, from 2-color to 8-color presses. A perfecting speed up to 15,000 SPH and RMGT's high-precision sheet turning technology combine to deliver both high productivity and exceptional printing quality.

Double/double/single-diameter cylinder perfecting mechanism

A double/double/single-diameter cylinder perfecting mechanism is equipped as standard. A cylinder with a large radius of curvature prevents sheet flapping and ensures stable sheet transport.

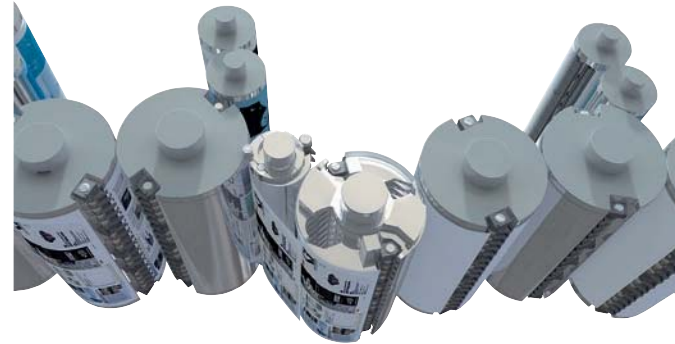

Double/double/single-diameter cylinder perfecting mechanism

High-speed perfecting NEW

Perfecting of fliers, pamphlets, publications, and a variety of double-sided printing can be performed at a high speed up to 15,000 SPH. To achieve this high-speed perfecting, in addition to a tail-edge suction mechanism, the 970 is also equipped with a new segment vacuum cylinder that securely grips and holds the sheet, ensuring high-precision sheet turning during perfecting. Switching between straight printing and perfecting can be accomplished in less than 2 minutes via the touchscreen monitor, enabling quick job changeover.

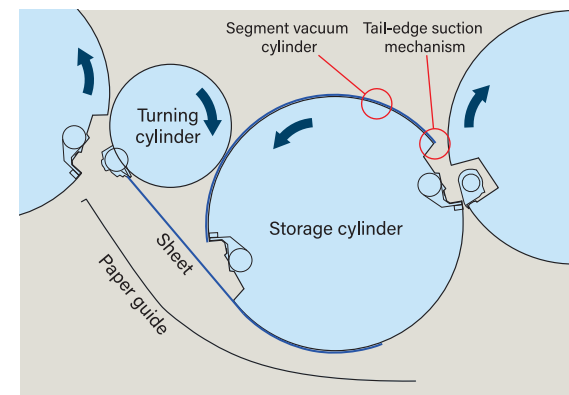
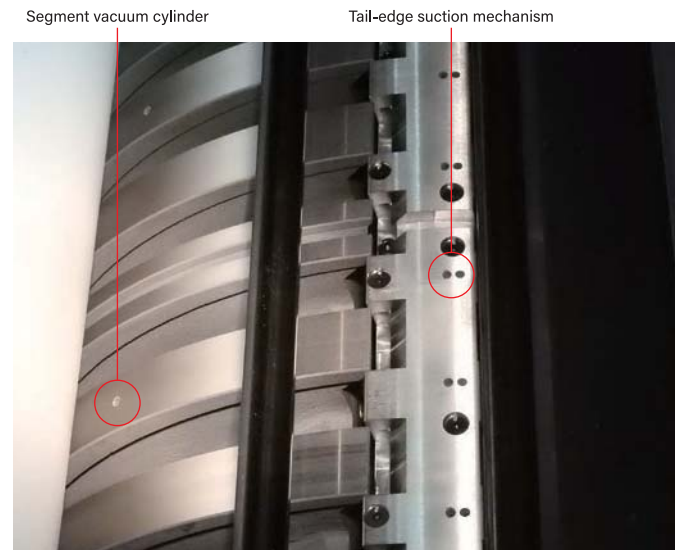

Diagram of the turning cylinder and storage cylinder



Segment vacuum cylinder and tail-edge suction mechanism

Delivery belt guide (perfecting models for oil-based ink printing) NEW

The delivery section's belt guide rotates at a synchronous speed with the transported sheets. This minimizes scratching or marking of the preceding printed side during sheet transport to the delivery section when perfecting using oil-based ink, ensuring high printing quality.

Delivery section belt type vacuum slow-down wheels (perfecting models for oil-based ink printing) NEW

This mechanism more effectively slows down sheets during transport to the delivery section and also improves piling performance. The wheels can be positioned to the outside of the printed area according to the printing image and sheet size, ensuring stable delivery for thin to heavy stock.

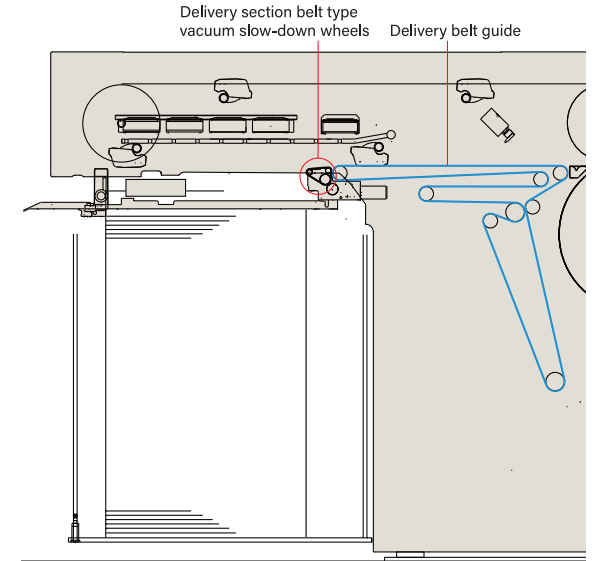
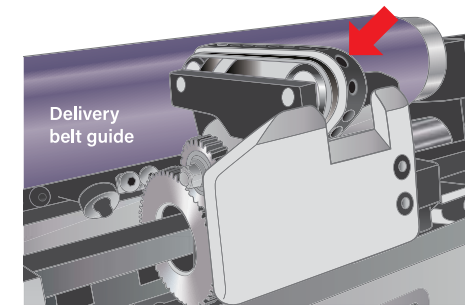

Instant drying perfecting (models with LED-UV/UV curing unit)

LED-UV/UV curing units over the perfecting device and at the delivery section make it possible to perform perfecting with instant drying of both printed sides. The printed sheets can then be immediately sent to post-press processes such as trimming and binding. Eliminating the need to wait for them to dry flexibly meets the demand for shorter lead times.

LED-UV curing unit

The power consumption of the LED-UV curing unit is only about 63% that of a conventional UV lamp system. Since the LED-UV light source instantly switches on and off, standby power consumption is also greatly reduced. Another advantage is that the LED-UV system operates at a UV wavelength that generates no ozone, so there is none of the ozone odor peculiar to UV printing. The LED-UV curing unit also generates much less heat, so there is no need to install ducts for ozone and heat exhaust, and there is less chance of heat affecting the printing substrates. Plus, a clean work environment can be maintained since no spray powder is used.

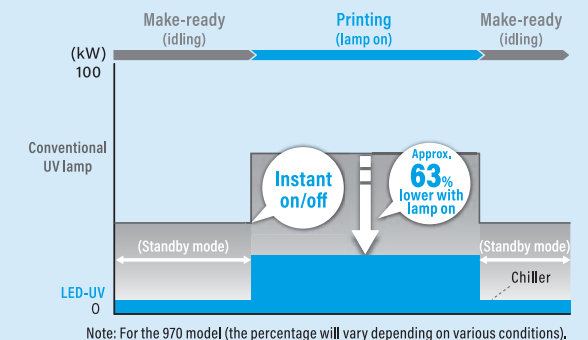

Operator Assist Functions

Advanced assist functions reducing the operator's labor.

RMGT's advanced technology provides powerful operator assistance—from make-ready tasks to printing, cleaning and maintenance—to meet the growing need for automation and labor-saving.

Press Information Display*

The real-time status of sheet transport is captured by network cameras for viewing on the live-view monitor. The Press Information Display features functions for displaying image data, job progress, printing density measurement results, the operating status of safety devices, and other information. The Press Information Display is also available with Press Information Edge, a platform for connecting to the printing company's ERP system. (The basic configuration is 3 network cameras, with up to 10 cameras installable.)

* Option



Feeder/delivery section touchscreen monitor NEW

Various feeder section operations, settings and checks can be performed via a touchscreen monitor, including starting a print run, counter setting, feeder air presetting,* and feed timing checker operation. Delivery section settings such as adjustment of the back guide and side guide as well as adjustment of the delivery fan volume are also performed using a touchscreen monitor, greatly simplifying delivery section tasks. Both operation panels are equipped with error description displays and other monitoring functions to assist the press operator.

* Option

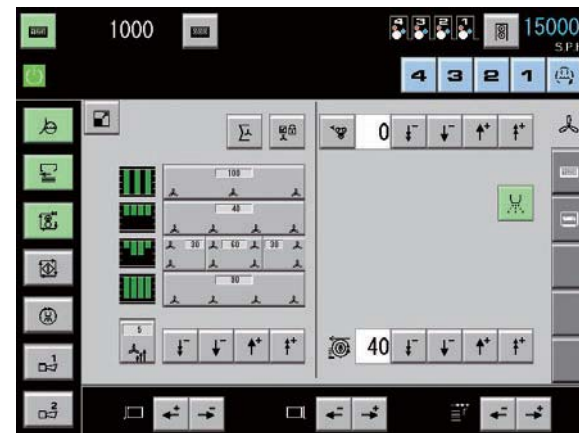

Delivery section touchscreen monitor

Maintenance mode

The one-touch nip pressure adjustment position cue function and automatic roller nip pressure checking function reduce the labor required for maintenance work. Nip checking is remarkably easier thanks to the nip-checking mode that prints the actual nip width in a single sheet pass.

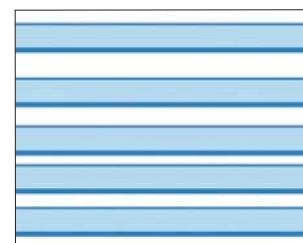

Example: Nip-printed sheet

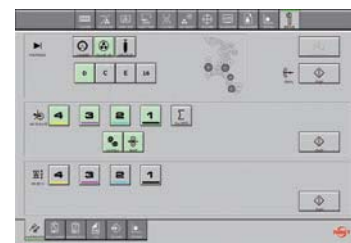

Maintenance mode screen

Automatic cleaning devices

The automatic blanket cleaning device* and automatic ink roller cleaning device* greatly reduce the time and labor needed for cleaning and changing colors during job changeover. Custom setting and program registration can be performed to activate each cleaning device according to the level of cleaning required.

* Option

PDS-E SpectroDrive/SpectroJet* — Printing Density Control Systems

The color bar on printed sheets is measured and the differences in solid and halftone densities from the standard values are calculated. Using a predictive density control system, the ink correction value is calculated from those differences. The opening of the ink fountain keys is then automatically controlled to quickly match the printing densities to the target values.

By numerically managing ink density, a task that previously relied on operator experience and intuition, color adjustment can be quickly and accurately performed, reducing sheet waste and maintaining consistent printing quality.

* Option



PDS-E SpectroDrive

PQS-D (I+C+R) Printing Quality Control System*

A CCD camera installed on the press captures images of the printed sheets to perform inline quality inspection, printing density tracking, and automatic register control without pulling out sheets.

• Quality inspection function (I)

Hickeys and other marks are automatically detected, and the location and type of each defect is displayed. The defective sheets can also be sorted out using a tape inserter.

• Printing density tracking function (C)

During printing, the CCD camera records images of the color bars on the printed sheets for comparison with the target density. The ink keys are then automatically controlled to eliminate any difference in density.

• Automatic register adjustment function (R)

The CCD camera captures images of the special registration marks and the registration is automatically adjusted.

* Optional configuration combining the PQS-D (C) and PQS-D (R) with the PQS-D (I).



CCD camera

Smart Assist Printing*1*2 NEW

Enabling nonstop printing of multiple jobs at the touch of an onscreen button, Smart Assist Printing automatically performs a series of printing processes from ink presetting, blanket cleaning, and plate changing to test printing, register adjustment, density adjustment, and production printing. In conjunction with the PQS-D system, printing quality inspection, density adjustment, and registration adjustment are performed automatically without sampling printed sheets. The result is highly efficient job changeover for short-run printing.

For jobs that demand quality inspection by the operator, production printing can begin with visual verification after test printing.

*1 Option

*2 Smart Assist Printing requires the following optional devices.

- Automatic blanket cleaning device • Impression pressure presetting device • PQS-D (I+C+R)
- FPC fully automatic plate changing system or Smart-FPC fully automatic simultaneous plate changing system • PDS-E SpectroDrive/SpectroJet
- Press Information Display or Press Information Edge • PPC server III or Ink Volume Setter • Tape inserter

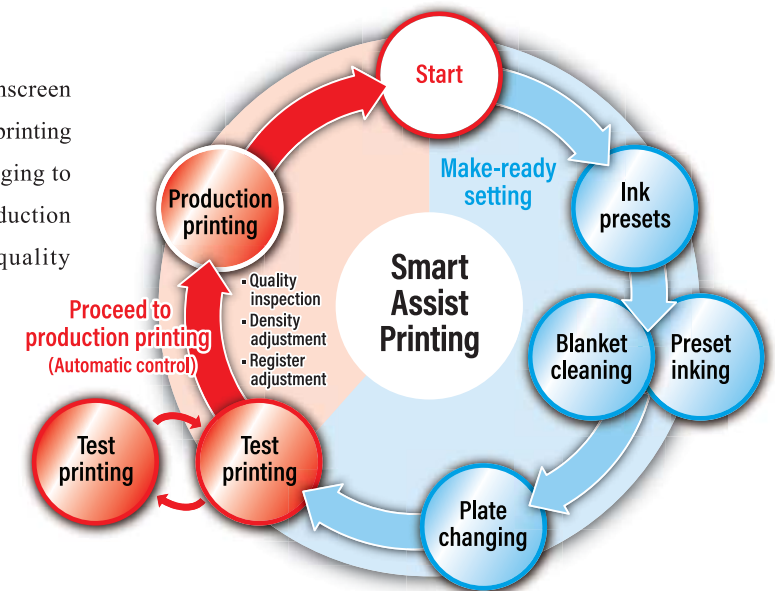

High Value-added Printing

Varnish coatings, special colors, and other options make it possible to add new value to printed materials.

From commercial printing to small-lot package printing, the ability to offer varnish coatings, special colors, and printing on non-absorbent materials creates new business opportunities.

Retractable chamber type coating unit

The chamber type coating unit can apply a wide selection of aqueous and UV varnish coatings from packages to book covers, novelty and sales promotion materials, and greeting cards. When not in use, the coating unit retracts upward and a safety guard moves into position, enabling preparations for the next job to be performed while printing is in progress.

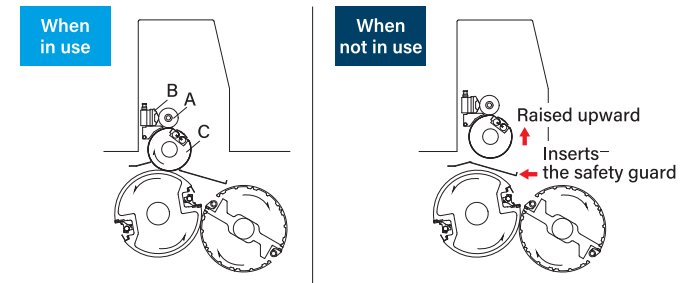

A. Anilox roller B. Varnish chamber C. Coating unit



Chamber type coating unit

Combining a coating unit and LED-UV/UV curing unit for high value-added printing

High-power LED-UV/UV curing unit can be installed at the delivery section and over the printing unit impression cylinder or convertible perfecting device. By installing the necessary wiring and piping beforehand, the LED-UV/UV curing unit can be flexibly mounted over the impression cylinder to suit the type of printing. This makes possible a wide range of high value-added printing, such as printing a white layer on metallized paper prior to process color printing, printing on a film substrate, or chemical embossing printing using UV varnish.

[Example of chemical embossing printing using a 970ST-5 + coating unit + LED-UV + semi-long delivery]

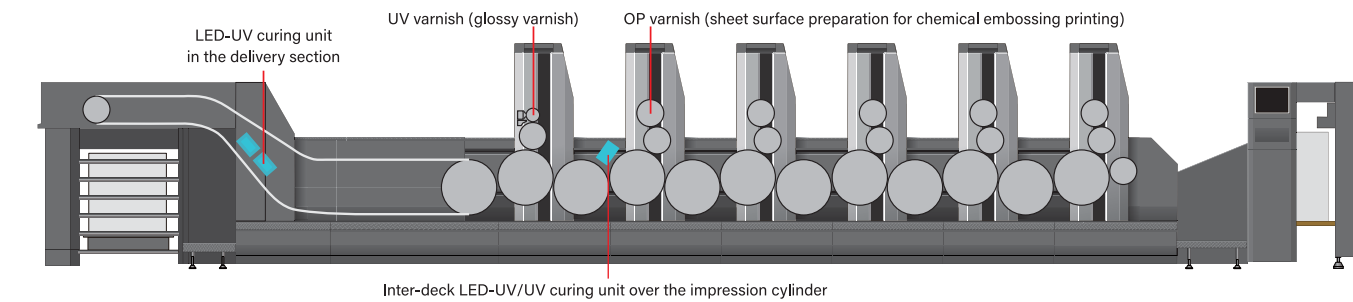

LED-UV curing unit in the delivery section



Inter-deck LED-UV curing unit over the impression cylinder

Combination Chart

970ST straight press

970ST-5 + standard delivery

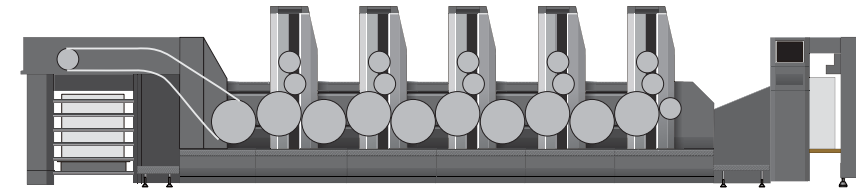

970ST-4 + coating unit + infrared dryer + semi-long delivery

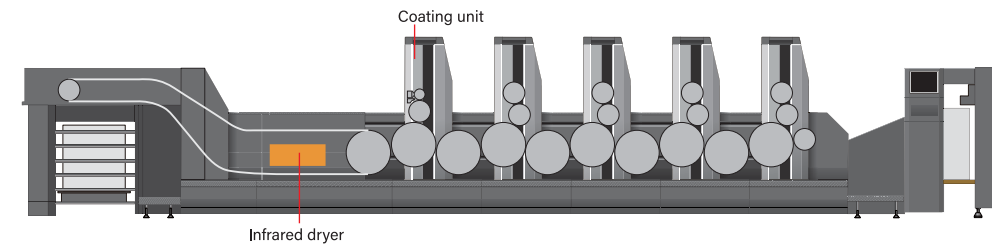

970ST-5 + coating unit + UV + long delivery

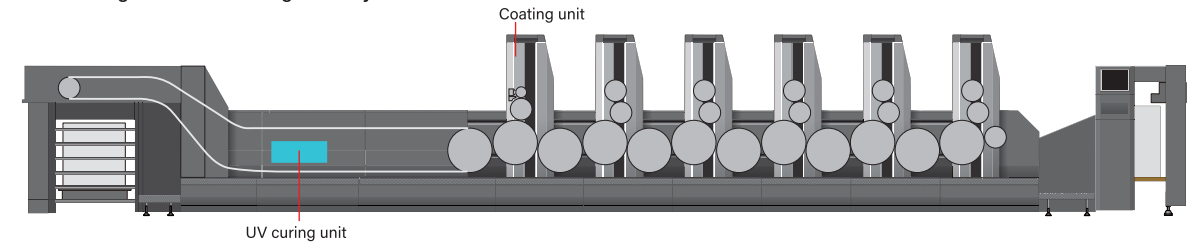

970ST-6 + coating unit + infrared dryer + LED-UV + semi-long delivery*

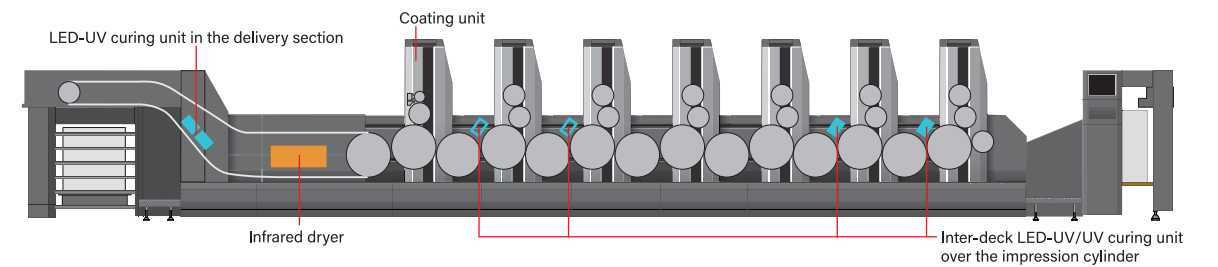

* The interdeck LED-UV/UV curing unit over the impression cylinder can be moved from between the 1st and 2nd printing units to between the 5th and 6th printing units.

970PF convertible perfector

970PF-4 + cylinder type delivery

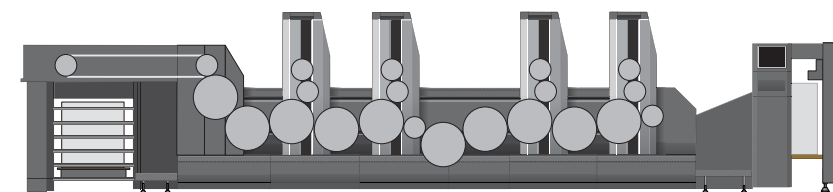

970PF-8 + LED-UV + standard delivery

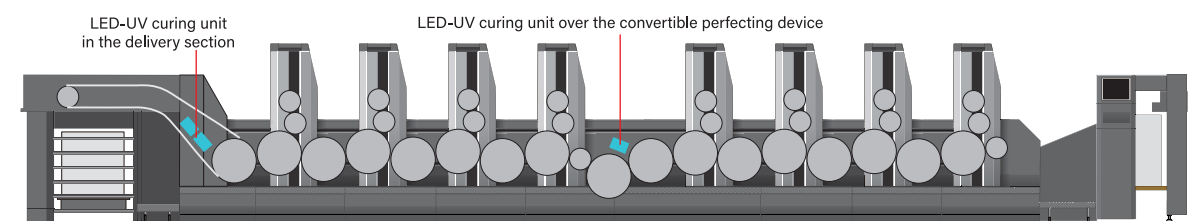

RMGT Smart Net

Workflow optimization through network connection

A workflow in which all equipment, systems, and processes required for producing printed materials are connected via network can be set up, providing powerful support for a “smart” printshop.

Visualization of printing processes and support for automation and

AGV operation significantly reduce the burden on staff and improve print shop efficiency.

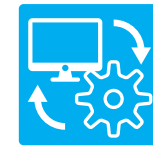
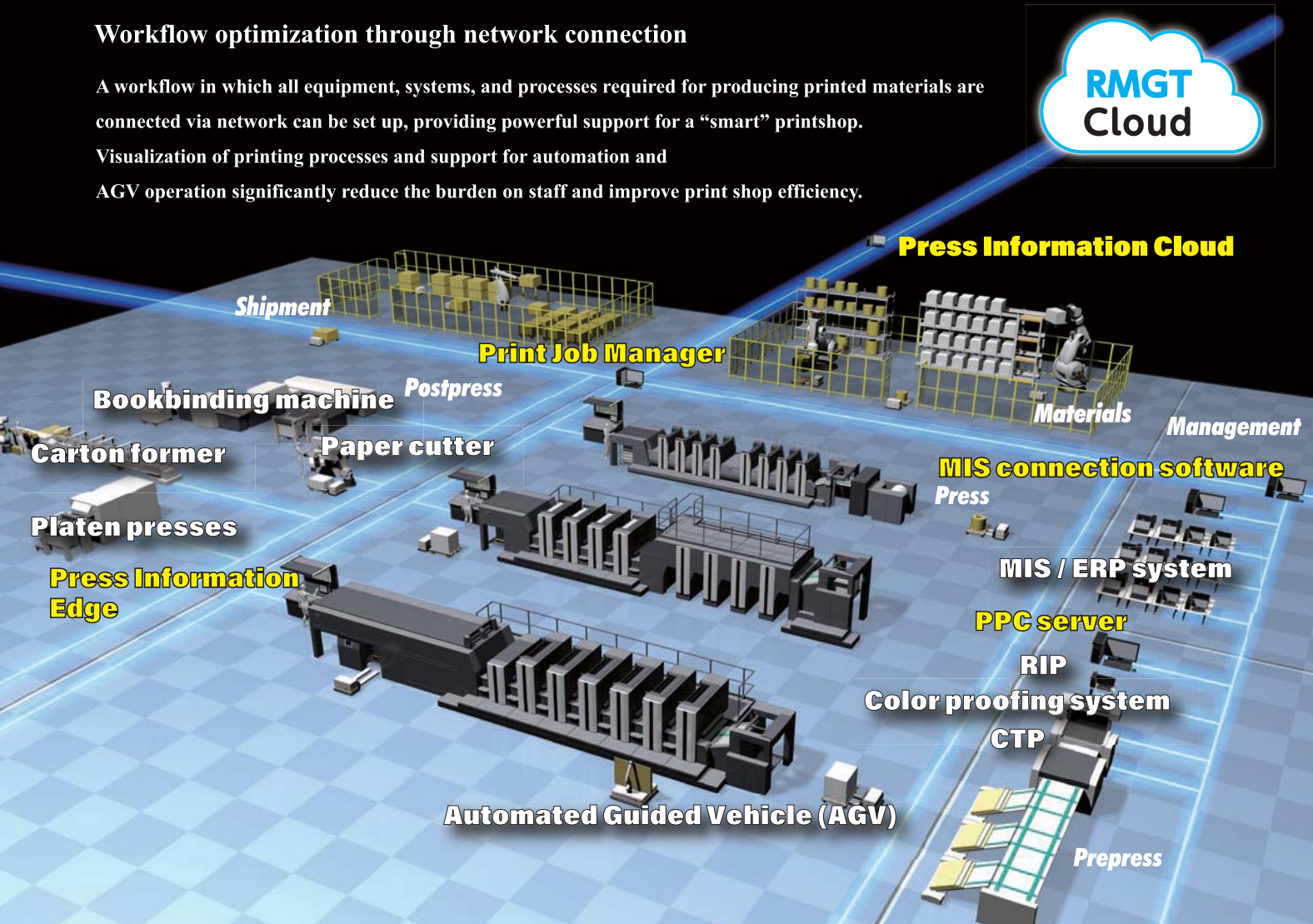

Supporting automation

Press Information Edge

Job data including paper size and ink is received from the printing company’s ERP system, then printing job data automatically linking the image area ratio data is generated. The job data is then sorted by sheet size, sheet thickness, and other parameters and integrated with the Smart Assist Printing functions for optimized automatic operation. The resulting press operation data is also automatically uploaded to the Press Information Cloud. Press Information Edge is a platform that connects the printing company’s ERP system, presses, peripheral equipment and Press Information Cloud.

[Optimal job order sorting] **NEW**

Printing jobs are automatically sorted into the optimum order according to sheet size, thickness, and other printing conditions, reducing the amount of time required for tasks such as changing the paper and colors during job changeover.

Job name	Sheet	Printer	F	B	SP cost(P)	SP cost(S)	Print schedule
001920-1 Page.001 catalog1	15000	OK Toccoat(Octavo)	636.0 × 939.0 (0.10)				2020/04/30 (115 min.) (1 day)
001680-1 Page.003 News	20	OK Toccoat(Octavo)	636.0 × 939.0 (0.10)				2020/05/03 (25 min.) (0 day)
1870 Page.000 Notebook	15000	Glossy Paper(Octavo)	636.0 × 939.0 (0.08)				2020/04/29 (5 day)
001680-1 Page.001 catalog2	30000	Glossy Paper(Octavo)	636.0 × 939.0 (0.08)				2020/05/07 (205 min.) (0 day)
2050 Page.001 Poster1	30000	Coated Paper(Octavo)	636.0 × 939.0 (0.08)				2020/04/30 (205 min.) (0 day)
001680-2 Page.005 catalog3	15000	Coated Paper(Octavo)	636.0 × 939.0 (0.08)				2020/05/05 (115 min.) (0 day)
001680-3 Page.002	30000	Coated Paper(Octavo)	636.0 × 939.0 (0.08)		OK	OK	2020/05/07

Sorting order changing screen



Supporting visualization

Press Information Cloud

By centrally collecting, managing, and analyzing the operation data for each press, it is possible to visualize the operating conditions, production rates, and improvement targets for each printing process.



Production report
Displays production data such as sheet waste, operation rate, efficiency, and daily statements.

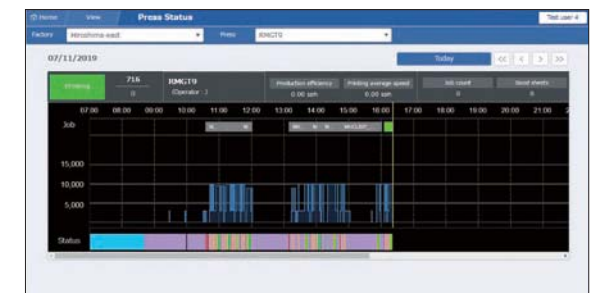

Press status
Displays the production status of a press.

RMGT Smart Factory Solution Concept

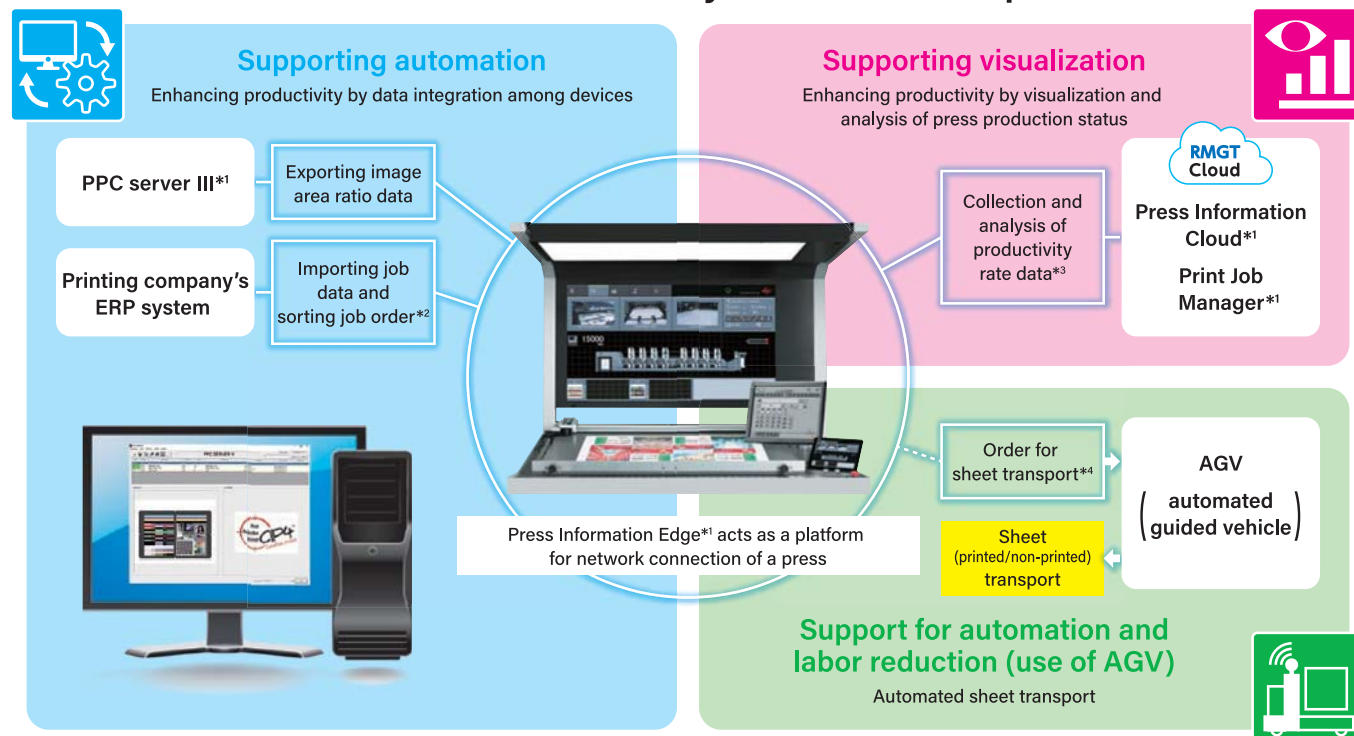

*1 Option *2 Press Information Edge is needed for importing job data and job order sorting.
*3 Press Information Edge is needed to connect with Press Information Cloud. *4 Wireless connection. Requires Press Information Edge.



Support for automation and labor reduction (use of AGV)

AGV (automated guided vehicle)

Based on the press operation status, Press Information Edge sends commands to the feeder section to supply sheets and to the delivery section to remove the printed sheets. In accordance with those commands, sheets are automatically supplied and printed sheets are automatically removed and transported to the next process.

Note: In case of an inquiry of AGV with required interface arrangement for the overseas territories, please kindly contact the RMGT Distributors or the International Sales and Marketing dept.